

## // WEAR PROTECTION PRODUCTS

// TUBES AND ELBOWS WITH CERAMIC PROTECTION FOR PNEUMATIC TRANSPORT  
// CERAMIC LINING FOR LARGE SURFACE

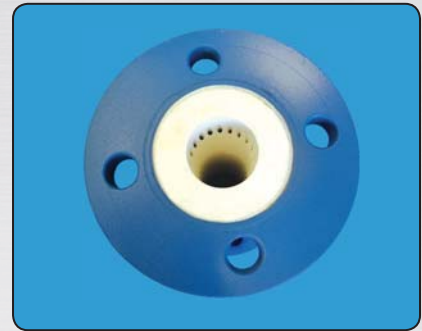
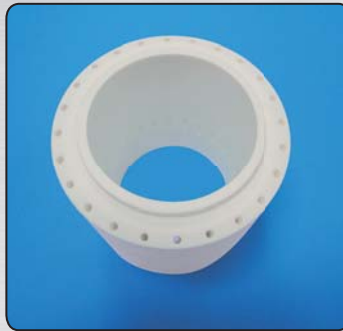

### CONVEYOR NOZZLE

Conveyor nozzles are used to accelerate transport with injecting the air in very long transport pipelines. These nozzles are made from ceramic segments which have more than 30 inlets around the scope of nozzle. These inlets are directed in the centre of the tube and that provides consistent air pressure of transport media. At the moment, this is the best solution in technology of pneumatic transport.

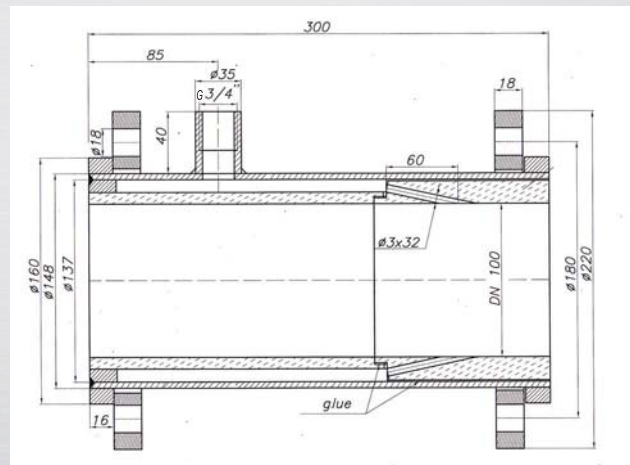

### CONNECTION OF METAL TUBE AND METAL-CERAMIC TUBE

STANDARD JOINT

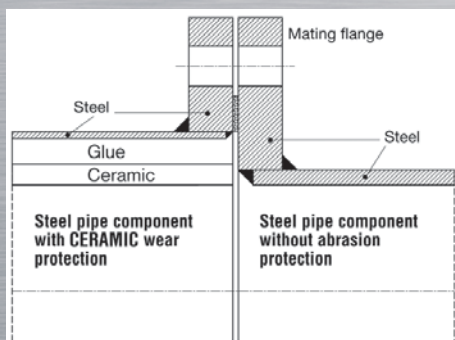

JOINT WITH CONNECTION FLANGE

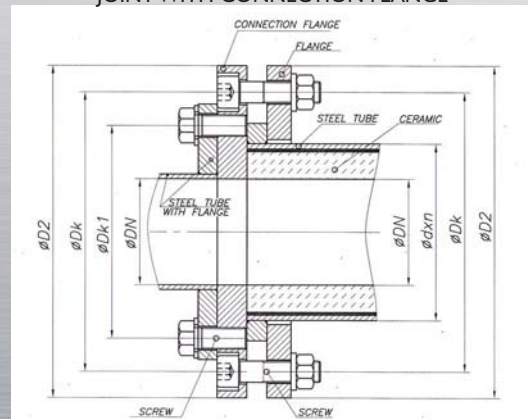



Tubes and elbows with inner diameter of ceramic up to DN 200 mm are made from ceramic cylindrical segments, which have male and female parts (see photo up left). At assembly this assures high quality of joint and long life time.



Tubes and elbows which have inner diameter bigger than DN 200 mm are lined with panels (mosaics) or with cone ceramic plates with requested thickness. Cone plates are adjusted to diameter of the tube or elbow, which are lined with ceramic.

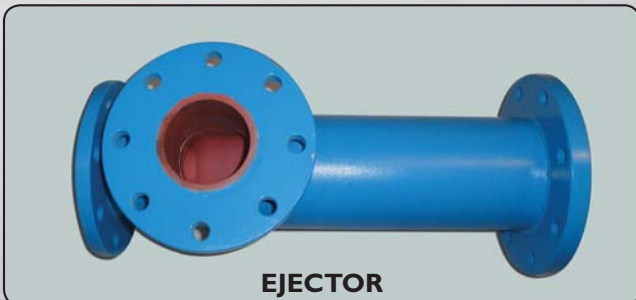

**EJECTOR**

Photos show different positions, which are lined with ceramic, due to big exposure to abrasion.

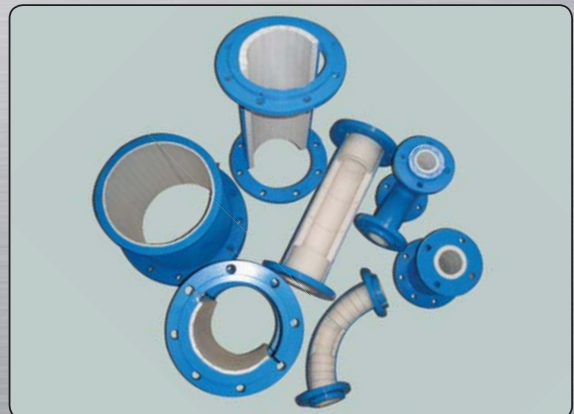

---

## AVTO G ELECTRONIC CONTROL SYSTEM OF CERAMIC WEAR IN PNEUMATIC TRANSPORT SYSTEMS

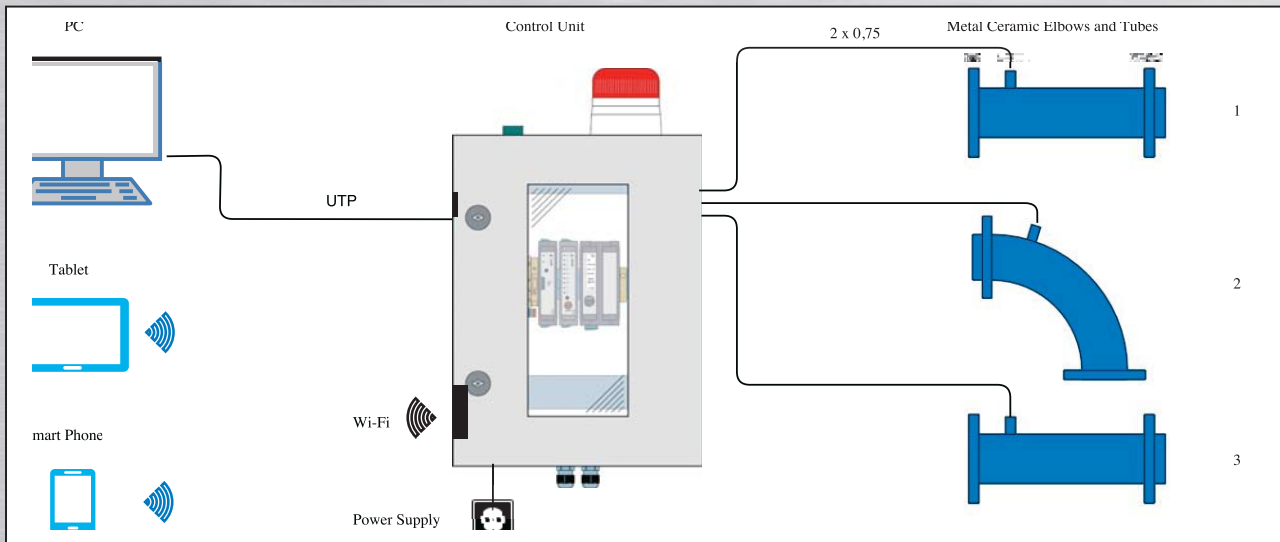

**Current problems of uncontrolled lining wear in pneumatic transports are over. We developed special Avto G electronic control system, which provides complete control of metal ceramic wear in pneumatic transport.**

**Avto G electronic wear control system provides You with following useful information:**

- It informs You on time, if tubes or elbows are worn out and if they must be replaced
- It informs You exactly which element in the pipeline and on which place it must be replaced
- It informs You when was this element installed and for how long it has been working
- And it can provide You with many other custom made information

**The system automatically gives You a light/alarm signal, when the elbow or tube is damaged, which can be also seen on Your PC-computer, tablet or smart phone. After the signal, You know that ceramic lining is already worn out, and that You still have only metal tube left, as a protection. It means that after the signal, You still have time to order new tube or elbow. Therefore our electronic control system prevents unpredictable breakthroughs and unnecessary stopping of production.**

**We hope our system will help You to improve Your production efficiency and make Your future easier.**

---

---

## FLEXIBLE TUBES FOR TRANSPORT OF VERY ABRASIVE MATERIALS



In Pneumatic transport systems, where exact dimensions of tubes and bends can not be defined, ceramic lined flexible rubber tubes can be used. Ceramic lining is produced according to principle male-female part in shape of joint, what makes the rubber tubes more flexible and allows bending in every direction.



The advantage of our ceramic lined flexible tubes is, that the complete inner surface of rubber tube is covered with ceramics. The rubber tube is reinforced with metal net and can withstand the pressure until 10 bar.

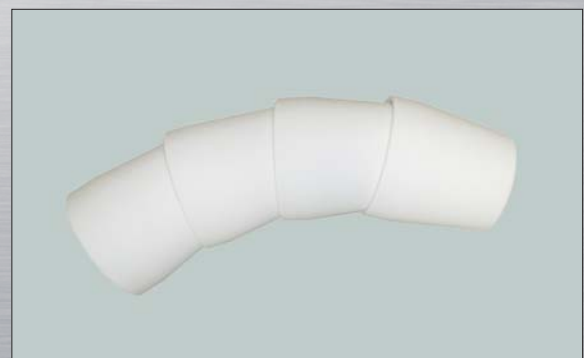

Our ceramic lined flexible tubes can also be produced with electronic control system, so we can successfully monitor wear of ceramic on computer, iPad or mobile phone.

---

## MATERIALS

Materials that are used for protection of elbows and tubes are:

- Aluminium Oxide 95%  $\text{Al}_2\text{O}_3$
- Aluminium Oxide 99,5%  $\text{Al}_2\text{O}_3$
- Composite  $\text{Al}_2\text{O}_3 + 10\% \text{ZrO}_2$   
(Aluminium Oxide + Zirconium Oxide)
- Zirconium Oxide  $\text{ZrO}_2$

## MECHANICAL PROPERTIES

The widest application of ceramics comes from its excellent mechanical properties.

High hardness and wear resistance, modulus of elasticity, comprehensive and flexural strengths have enabled the application of ceramic parts there where high mechanical stresses are experienced.

Such high strength of  $\text{Al}_2\text{O}_3$  ceramics is maintained at high temperatures and high abrasiveness, what makes it an excellent replacement for majority of metals, glasses, plastics, etc.

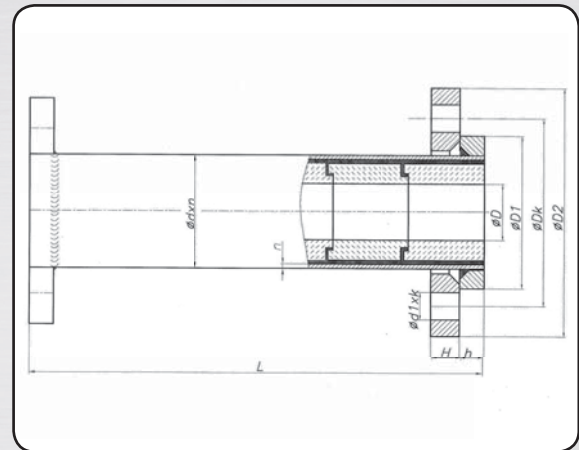
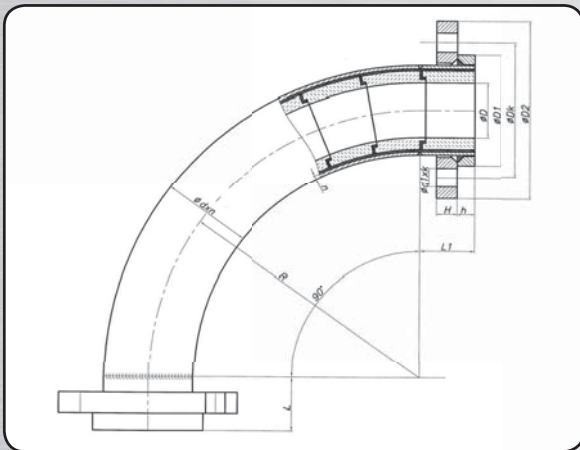
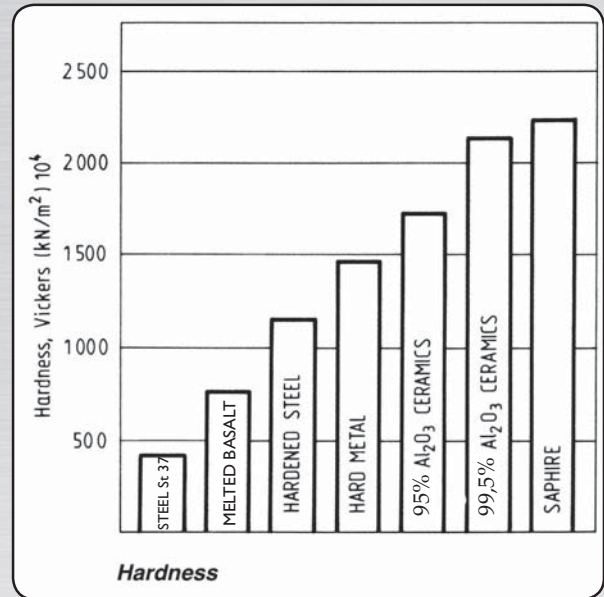

## APPLICATION:

Elbows and tubes with ceramic lining have wide application in different industries like pneumatic and hydraulic transport.

The most common applications are:

Industry:	Material:
1. Abrasive products	Grinding wheel granules
2. Aluminium plants	Calcined alumina, bauxite, electrode, carbon, crushed bath
3. Iron & Steel	Sinter dust, limestone, lime injection, coal, iron carbide, alloy additives
4. Mineral wool & insulation products	Perlite, stone dust, refractory fibers, production wastes, dust from sawing operations
5. Foundries	Molding sand, dust collection
6. Glass plants	Batch, cullet, quartz, kaoline, feldspar
7. Breweries, grain processing, feed mills,	Corn, barley, soy beans, malt, cocoa beans, sunflower seeds, rice hulls, malting plants
8. Cement	Clinker dust, limestone, cement, fly ash, coal, blast furnace slag
9. Chemical plants	Caustic lime, fertilizers, lime dust, chrome ore, paint pigments, plastic pallets with glass fibers
10. Mineral mining plants	Kiln feed, ore concentrate, coal tailings, dust
11. Coal fired power stations	Coal, fly ash, pyrites, slag, ash, limestone
12. Coal mines	Coal dust, mine waste for backfilling
13. Technical carbon products	Technical carbon, dust, graphite for electrodes



Ceramic cylinders and cones are produced by isostatic pressing and they provide long lifetime of different pipelines, dosage machines for powder materials, different nozzles and other products.



#### WEAR TESTS ON DIFFERENT MATERIALS:

Sample	CERAMICS 99,5% Al <sub>2</sub> O <sub>3</sub>	CERAMICS 95% Al <sub>2</sub> O <sub>3</sub>	MELTED BASALT	RUBBER	STEEL
Density ( gr/cm <sup>3</sup> )	3,85	3,7	2,95	1,18	7,85
Mass wear ( gr )	0,007	0,009	0,12	0,2	1,51
Volume wear ( cm <sup>3</sup> )	<b>0,0026</b>	<b>0,0028</b>	<b>0,04</b>	<b>0,17</b>	<b>0,19</b>

Test is made under following conditions:

- Radiation angle : **30°**
- Pressure : **5 bar**
- Time : **5 minutes**
- Abrasive material : **SiO<sub>2</sub>**

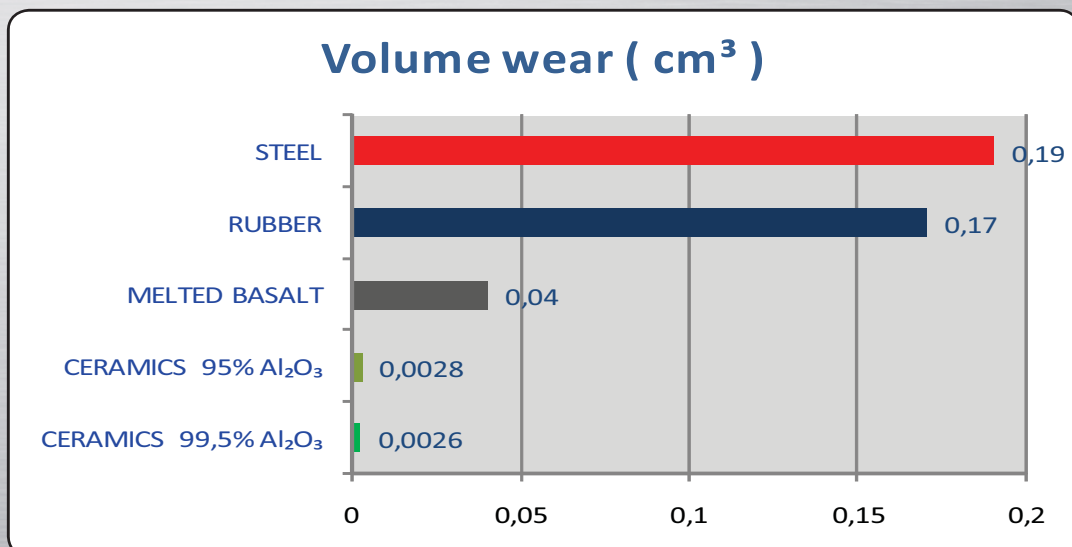

---

## CERAMIC LINING FOR LARGE SURFACE

For lining of large surfaces as well as for different shape of surfaces, we use different ceramic tiles (plates) and different mozaics. Material that we use is 92% Al<sub>2</sub>O<sub>3</sub>, 95% Al<sub>2</sub>O<sub>3</sub> and 99,5% Al<sub>2</sub>O<sub>3</sub>.

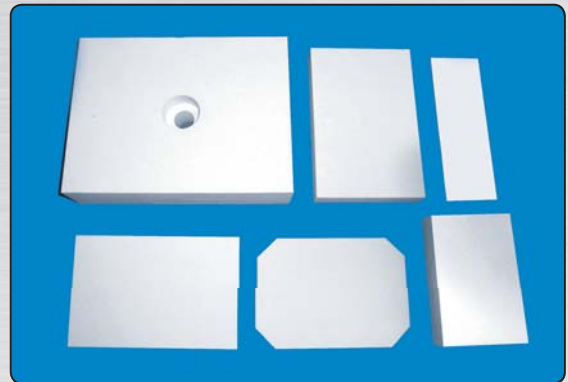
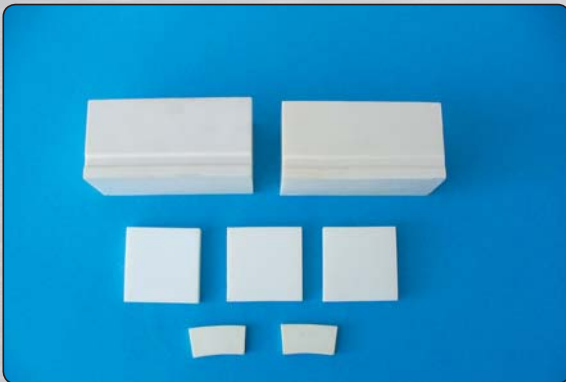

We make ceramic tiles (plates) in different sizes and thicknesses; it depends on operating conditions and place where they are mounted. Tiles are fixed with special epoxy glue that has very good properties of fixing.

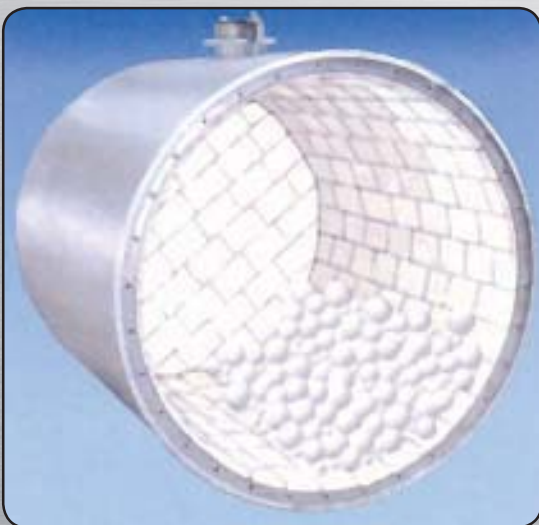

Photos show plates with different shapes for lining of surfaces, which are exposed to abrasion.

---



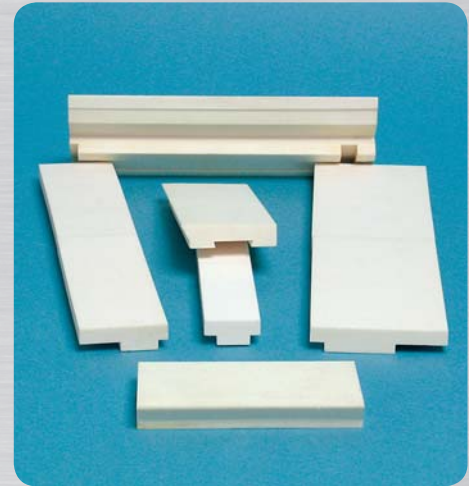
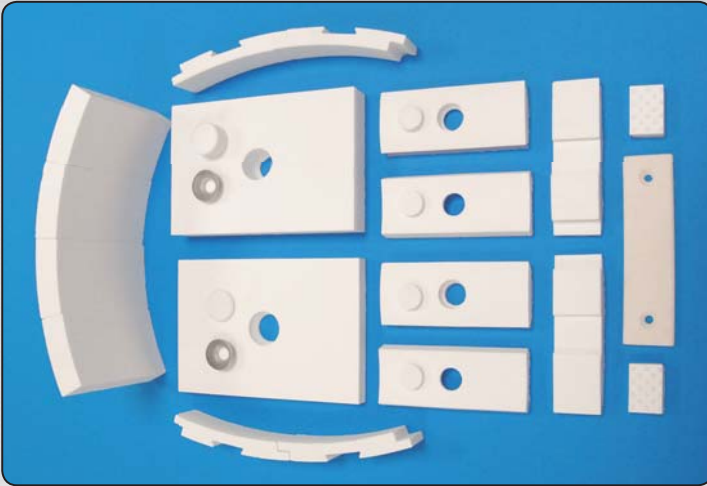

At lining of surfaces, which are exposed to high temperatures and vibrations, epoxy glue is not enough to assure the quality of metal-ceramic. Plates with holes are beside glue, additionally fixed to surface with steel ferrule, which is welded on it, or it is adjusted to surface with screw and nut. Some plates can be adjusted mechanically, because they have swallows tale.

#### ADJUSTING OF CERAMIC PLATE ON SURFACE WITH WELDING OF STEEL FERRULE

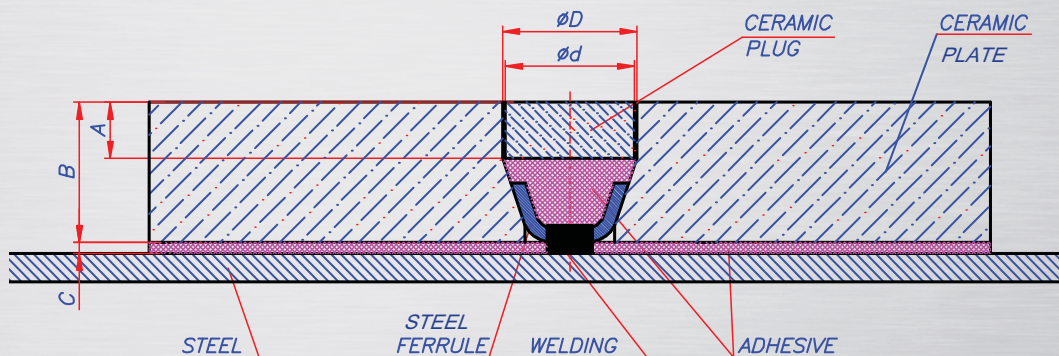

#### ADJUSTING OF CERAMIC PLATE ON SURFACE WITH SCREW AND NUT

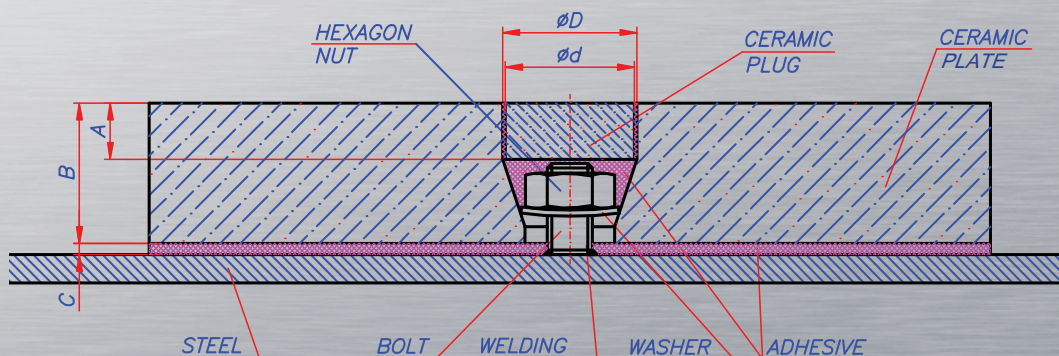

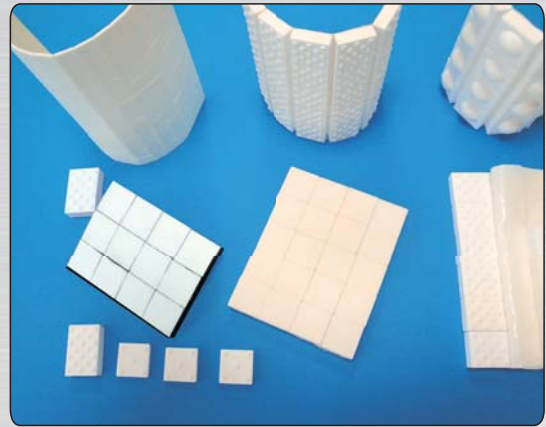
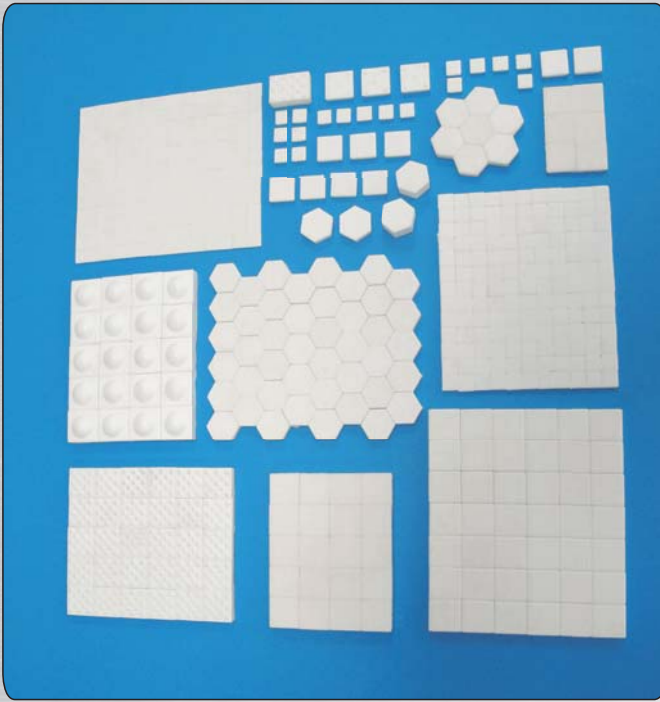

Besides standard panels (mosaics) we produce also special panels, on which ceramic has special shape (different convex parts, nipples). According to customers request we can also vulcanize panels in rubber, which makes the usage of panels bigger, on surfaces which are exposed to different vibrations and punches.

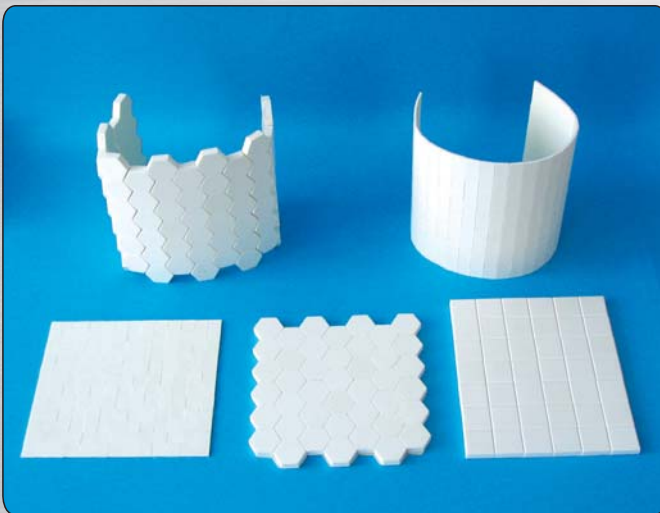

Ceramic mosaics are very suitable for lining of large surfaces, silos, irregular surfaces and many other shapes.

We produce following mosaics:

**SQUARE TILES:**

Ceramic tiles are glued on special acetat-silk material. The panel is 500 x 500mm large and we make them from following tiles:

- 10 x 10 mm, thickness: 2mm, 3mm
- 20 x 20 mm, thickness: 4mm to 12mm

**HEXAGONAL (SIX-ANGLE) TILES:**

Ceramic hexagonal tiles are glued on special acetat-silk material. The panel is 508 x 490mm large (696 psc of tiles). Type of tiles:

- SW 20 mm, (SW = distance between 2 sides), thickness: 4mm to 12mm

AVTO G d.o.o.  
Šlandrova ulica 4, 1231 Ljubljana  
Slovenia

T: +386 1 237 3510  
F: +386 1 237 3514  
E: info@avtog.com

[www.avtog.com](http://www.avtog.com)

